

# HORSE TRAILERS



**FEATHERLITE**  
TRAILERS



# BEST FOR YOU.

Discover what makes owning a new aluminum Featherlite horse trailer the best decision for you and your horses. Explore our wide array of models with enhanced features and options. Then contact your nearest Featherlite dealer or visit our website for even more details.

**DURABILITY.** With a Featherlite, you get our durable uni-body all-aluminum construction with superior resistance to rust and corrosion and minimal maintenance.

**RELIABILITY.** You have the peace of mind of owning a trailer with a 10-year limited structural warranty\* with 3-year hitch-to-bumper on select models.

**VALUE.** More features are standard with our Featherlite horse trailers than ever before. Enhanced features, durable all-aluminum construction, a transferable warranty\*\* and a longer life for your trailer thanks to Featherlite's quality construction equates to a higher resale value for you.

**SAFETY.** With Featherlite, you receive a trailer designed with features to give your horses a smooth, steady ride that will get you and your horses to your destination safely and securely.

Features and options may vary depending on trailer models and model year.  
Some trailers in brochure may be shown with options. White side sheets standard.





# THE 9000 SERIES

For over 50 years, Featherlite has been making history as a leader in the aluminum trailer industry. Leading the way in quality, durability, value and safety has been tradition for Featherlite. And now, the Featherlite team has engineered the next generation of Featherlite horse trailers – the 9000 Series – that continues to build upon that reputation.

## What's New?

- We've made ordering and selecting your trailer easier with a more streamlined selection of our most popular configurations. Models include the 9300, 9400, 9500, 9600, 9807 and 9808.
- Additional features – for both you and your horses – are now standard. That's extra convenience and value built into each trailer!
- Redesigned and enhanced living quarters décor packages are now available in Models 9807 and 9808.

# REDEFINING MORE.

These are some of the standard features you'll find with the 9000 Series horse trailers.



## SQUARED CORNERS

All unload doors, drop down feed doors and camper doors are now square cornered. The larger drop down feed doors allow even more light into the horse area.



## LOAD LIGHT

A rear LED load light and switch are now standard on all horse trailer models. In addition, this LED load light is even brighter than our previous offerings.



## MORE TIE RINGS

All horse trailers come with one exterior tie ring per horse on both sides of the trailer, providing more options when securing your horses.



## AIR FLO DIVIDERS

Our popular Air Flo dividers (previously optional) are now standard, allowing for more airflow in your trailer's horse area.



## WAVE PANELS

Aluminum 'wave' side panels, previously optional, are now standard on all horse trailer models, giving each trailer an elevated look.



## RIVETLESS SIDES

Featherlite horse trailers feature rivetless aluminum side sheets for a sleeker, smoother looking exterior.



## SPARE TIRE

For peace of mind, a matching spare tire and rim are standard on all 9000 Series horse trailers.



## REAR TACK

On applicable models, the rear tack wall is lined with sleek, white aluminum. In addition, turf is on the rear tack wall when halter bars are mounted in the rear tack. This allows for less wear and tear on the rear tack wall.

## INTERIOR LED LIGHTS

Featherlite horse trailers feature an enhanced style of LED lights inside the trailer for more brightness.

## REAR RAMP

When equipped as a standard feature or added as an option, our rear ramps have been engineered to be lighter and easier to use.

## REAR DOORS

Featherlite's rear doors on slant load models now come with stainless steel double pipe hardware and no center post.

## SIDE WALLS

Featherlite horse trailers are built with 1 5/8" side walls for a more uniform width throughout the trailer.

## ALUMINUM HALTER HOOKS

Featherlite's standard halter hooks are now aluminum for more durability.

Visit [www.fthr.com/9000series](http://www.fthr.com/9000series) for more details and information.





# BUMPER PULL TRAILERS

Stylish, compact and easy to tow, Featherlite bumper pulls are the perfect choice for beginner and veteran horse owners alike.



43" dressing room model shown.

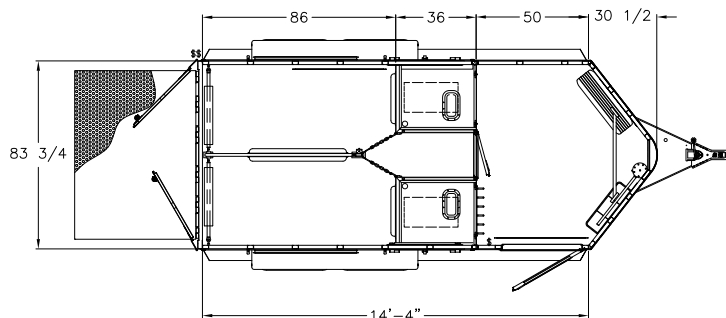

Floorplan shown: 50" with walk thru door.

## Model 9300

The straight load 2-horse bumper pull Model 9300 measures 7' wide and 7'6" tall with options of a 43" or 50" dressing room. The 50" dressing room includes a manger with walk thru door. The trailer features two 26" x 19" windows in the trailer's nose as well as a rear ramp, which is now easier to use.

# Model 9400

The slant load bumper pull Model 9400 is available in 2H, 3H and 4H floorplans with dressing room short wall options of 4", 24" or 48". The 9400, which is 7' wide, includes roomy stalls and double rear doors with stainless steel pipe hardware and no center post as standards. The great-looking and durable Featherlite aluminum 'wave' side panels as well as our Air Flo dividers are standard too.

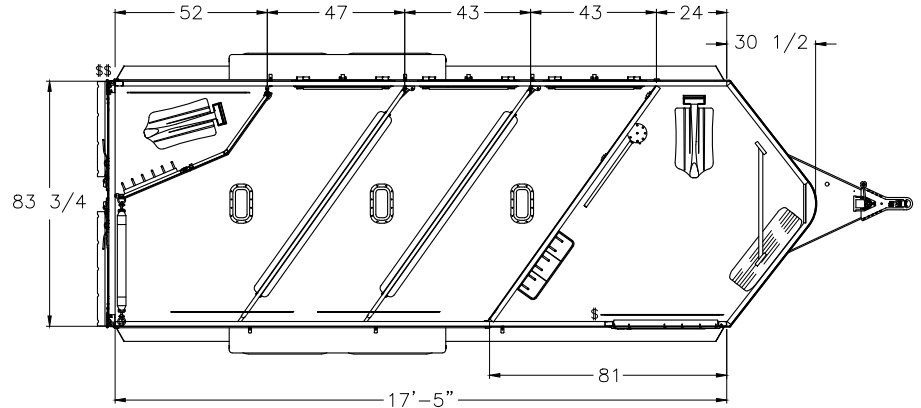

Floorplan shown: 3H with 24" dressing room.



# Model 9400 Premier Tack

For those that want an even more elevated horse trailer when traveling with your horses, the Premier Tack Model 9400 may be the choice for you. The Premier Tack features a 60" x 74" square double door and a 36" short wall dressing room. Features inside the tack area include a storage box, upright water caddy, turf, hanging clothing rod, stable fork, mirror and more.

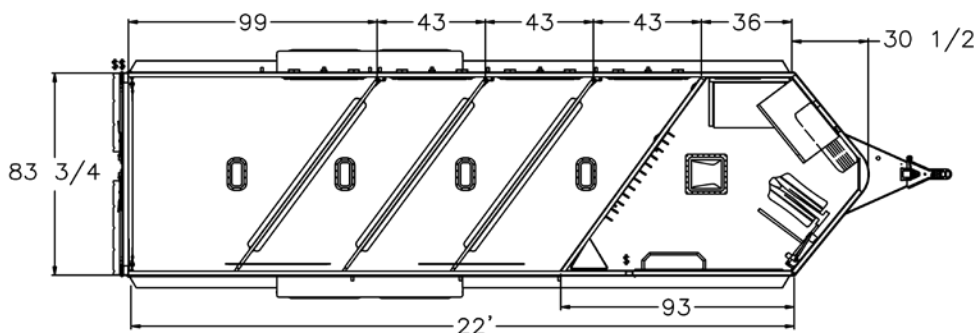





# GOOSENECK TRAILERS

Gooseneck horse trailers offer a carefully designed package of features as well as floorplans up to 6-horse to meet your hauling needs.

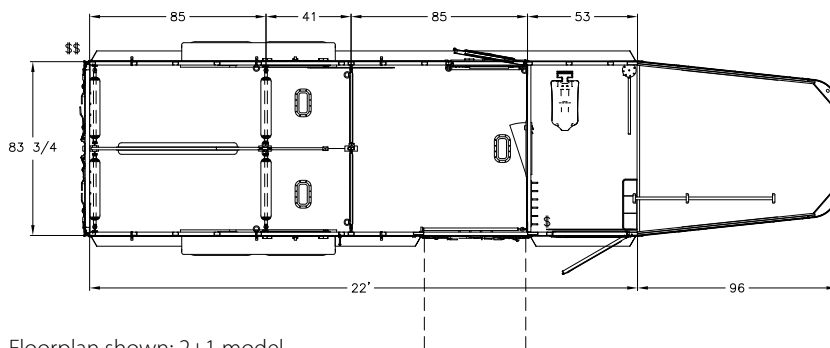

Floorplan shown: 2+1 model.

## Model 9500

The Model 9500 offers you a variety of options in a straight load gooseneck configuration. Choose from a 2H or 4H floorplan, including the 2+1 model or the floorplan with manger and walk thru door. Dressing room sizes are 53" or 58". A redesigned, easier to use rear ramp with double doors above is standard.

# Model 9600

Featherlite slant load gooseneck Model 9600 can haul 2 to 6 horses while you have the option of a 50" or 72" dressing room. This 7' wide trailer features a side unload door on 3H-6H models and double rear doors with stainless steel double pipe hardware and no center post. Bright white .040 aluminum lining above the wall rubber and Air Flo slant dividers are standard.

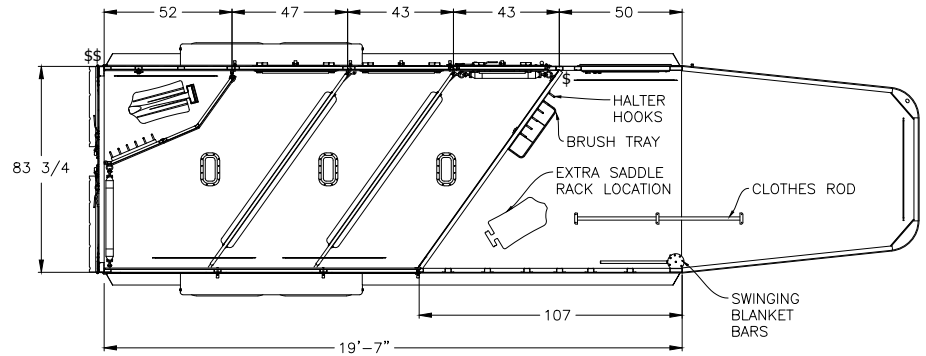

Floorplan shown: 3H with 50" dressing room.

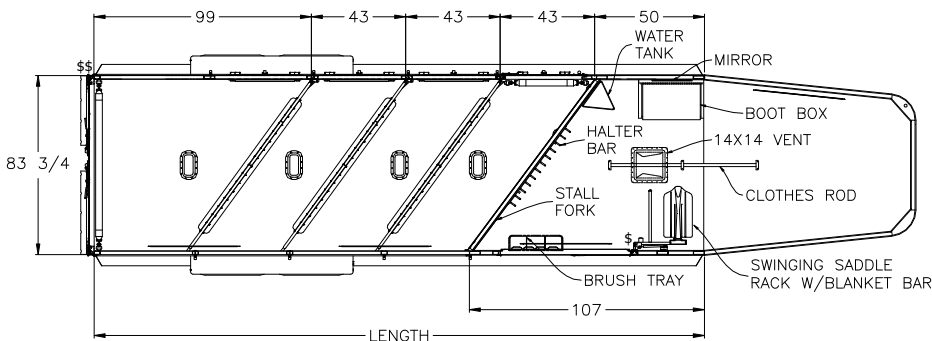

# Model 9600 Premier Tack

An enhanced tack room with extra amenities and easy access awaits horse owners in the Premier Tack Model 9600. Available as a 2, 3 or 4-horse, the 9600 Premier Tack features a 60" x 74" square double door and a 50" short wall dressing room. Features inside the tack area include a storage box, upright water caddy, turf, hanging clothing rod, stable fork, mirror and more.





# LIVING QUARTERS TRAILERS

Featherlite's horse trailers with living quarters offer well-designed décor packages and amenities so you can enjoy life away from home with your horses.

## Model 9807

The Model 9807 living quarters horse trailer gives you options of 8' and 10' living quarters floorplans inside a 2H, 3H or 4H model. This 7' wide trailer includes a pocket screen door standard, well-designed décor packages and rear doors with stainless steel double pipe hardware and no center post. You'll also discover aluminum halter hooks and one exterior tie ring per horse per side with the 9807.



## Model 9808

Featherlite living quarters Model 9808 is a spacious 8' wide with interior floorplans of 11', 13', 15' or 17'. Available as a 2H, 3H or 4H, you'll find white aluminum lining on the walls and ceiling, Air Flo dividers and a folding rear tack inside. A pocket screen door is standard, while you have various decor options and layouts to find the living quarters fit for you and your family.





# INTERIOR DÉCOR PACKAGES

Expertly designed interior décor packages are available in Featherlite's 9807 and 9808 living quarters models. These packages offer a blend of modern design and refined features that will create the ultimate living experience for you. From a more modern look to a warm western vibe to a classic and timeless interior, there's something for everyone!



## What stands out in Featherlite Interiors?

- THINSCAPE® solid surface countertops with full height backsplash in kitchen & bathroom
- New modern jackknife sofa with cupholders
- New thicker foam mattress
- Deep, extra large undermount kitchen sink
- Larger convection microwave standard
- Electric awning standard
- Updated media system
- Undermount LED courtesy lights optional





## BROWNSTONE LATTE

The Brownstone Latte interior decor package expertly blends classic and sophisticated design elements to craft a refined and relaxing interior for horse owners. Together, the rich warm woods of the cabinets and the earthy neutrals of the countertops and backsplash create an inviting interior tailored for equestrians.



### Features:

- THINSCAPE® solid surface countertops in Solenne Marble
- Dark rich cabinet color
- Full height mosaic tile backsplash in kitchen & bathroom
- Antique brushed aluminum pulls & knobs with arched details
- Taller, dual mirror cabinets in bedroom area with USB charging in center shelves
- Undermount brushed stainless steel sinks with new faucet style (27" single basin kitchen sink on most models)
- New modern sofa design with cupholders (USB chargers behind sofa)
- New "Dream Dinette" standard





## GLACIER ASH

Step inside the Glacier Ash interior décor package, and you'll experience clean, modern styling and refined features and accents. An attention to quality and detail means the Glacier Ash gives you all the comforts and conveniences you'll need while on the road with your horses.



### Features:

- THINSCAPE® solid surface countertops with full height backsplash
- Brushed gold door pulls
- Undermount black stainless sinks with new faucet style (27" single basin kitchen sink on most models)
- New modern sofa design with cupholders (USB chargers behind sofa)





# URBAN SADDLE

The Urban Saddle offers a warm and welcoming interior with a western vibe to give you the comfortable space you desire while traveling with your horses. The Urban Saddle interior is infused with light and natural elements that help to elevate your relaxation and time away from home.



## Features:

- Black veined THINSCAPE® solid surface countertops with full height backsplash in kitchen & bathroom
- Matte black faucets & hardware throughout kitchen & bathroom
- Natural light wood cabinets with deep brown accents
- Farmhouse inspired black metal accents on valances & pocket door
- New modern sofa design with cupholders (USB chargers behind sofa)



# STOCK COMBO TRAILERS

Stock combo trailers give you the flexibility to transport either horses or livestock. Bumper pull or gooseneck options are available.

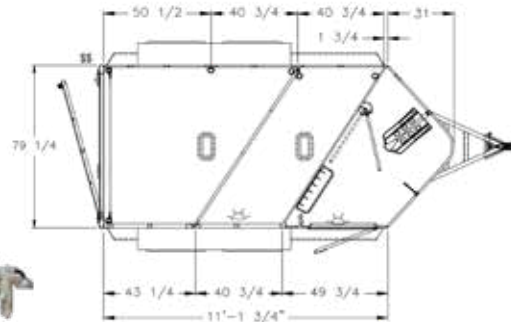

## Model 9651

Featherlite's bumper pull Model 9651 is available in a 2 or 3-horse configuration and features extruded aluminum side panels and air spaces. The trailer is 6'7" wide and 7' tall and comes standard with aluminum wheels, full swing rear gate and an LED load light.

## Model 9751

Featherlite's gooseneck Model 9751 is available as a 3 or 4-horse model and includes extruded aluminum side panels with air spaces and a full swing rear gate. It has a width of 6'7" and height of 7' with a 24" short wall dressing room. Standard features include aluminum wheels, 2 outside tie rings per horse and an LED load light.

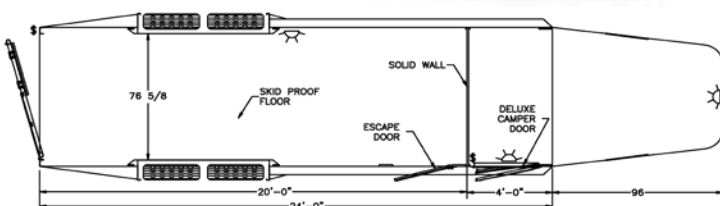
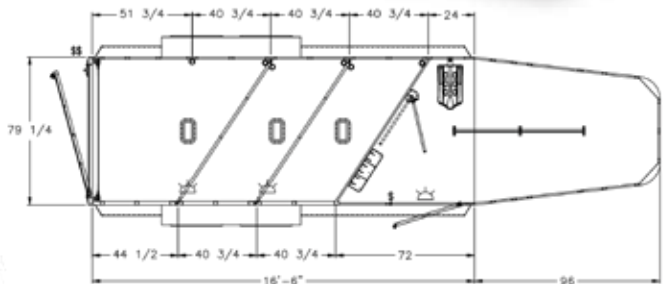

## Model 8413

The Model 8413 gooseneck stock combo trailer is set up to haul either livestock or horses with optional center gates to split the cargo area, allowing you to do double duty. Owners can configure the 8413 as a straight or slant load, and it's available in widths of 7', 7'6" or 8'. Available in lengths from 16' to 32', this model is fully customizable to fit your hauling needs.



# POPULAR OPTIONS

While standard Featherlite horse trailers are already equipped with many great features, you can easily add optional accessories for a horse trailer more suited to your needs. Be sure to visit your local Featherlite dealer to learn more about the full list of available options.



Black aluminum wheels



Boot box



Dual colored side sheets



Easy Care Flooring



Exterior graphics



Extra load lights



Fans in horse area



Feed bags



Hay rack



Polished aluminum panels



Rear ramp



Removable bottom half divider



Roof vent in dressing room



Swing out saddle rack



Turf on slant wall



White lining on ceiling

## Other options not shown:

Additional clearance lights

Curbside feed doors

Electric jack

Pocket screen door (non-LQ models)

Unload door (if not standard)

\* Some trailers may be shown with options.  
Not all features or options available on all models.



# TRANSFORM YOUR ROAD AHEAD

Go to [www.fthr.com](http://www.fthr.com) for more trailer specifications, floorplans and available options. Or visit your local Featherlite dealer and be on your way to owning a new Featherlite horse trailer.

Contact a Featherlite Dealer for Details. Your area dealer is:



< Want more information?  
Snap this with your smart phone  
to visit Featherlite's website.



Phone: 563-547-6000

Toll Free: 800-800-1230

Web: [www.fthr.com](http://www.fthr.com)

Email: [salesinfo@fthr.com](mailto:salesinfo@fthr.com)

Address: Hwy 63 & 9, Cresco, IA 52136

All dimensions shown in this brochure are approximate and may vary. Featherlite Trailers reserves the right to change or alter these specifications without notice. Some trailers shown with options. © 06/2024 Featherlite Trailers.

\*10-year warranty applies to new aluminum, non-commercial trailers. 3-year hitch-to-bumper warranty is available on most new models. Some models excluded. The additional 2-year hitch-to-bumper warranty applies to components manufactured by Featherlite only. Some restrictions apply. Contact your Featherlite dealer for specific details.

\*\*Effective April 1, 2009, transferable warranty is available only on a trailer with remaining warranty that is traded in for a new Featherlite trailer at an authorized