

HORSE TRAILERS



SAFE. SECURE. SMART.





YOURS FOR LIFE.

DURABILITY

With a Featherlite, you get our durable uni-body all-aluminum construction with superior resistance to rust & corrosion and minimal maintenance.

EASE OF USE

Featherlite's horse trailers are designed with features that are convenient and easy to use. Featherlite's spring-loaded slam latch dividers feature a quick and secure lock with no need for hands near the fastening point and a heavy-duty spring. Featherlite's drop-down feed doors and latches throughout the trailer are easy to use, often requiring only one hand.

VALUE

You get a higher resale value that comes from Featherlite's transferable warranty** and superior all-aluminum construction that resists rust, corrosion and wear. Premium Goodyear® tires are also standard on many horse trailer models, adding extra value to your Featherlite.

YOUR WAY

With Featherlite you get a large selection of options to personalize your horse trailer. Options available include a telescoping ladder with your hayrack of choice, thicker 2" stall pads for added safety, LED load lights, Easy Care Flooring and other conveniences. Plus, Featherlites are available in a variety of exterior colors including dual- and tri-colored options.

FUEL EFFICIENCY

You can get a lighter, smoother and more fuel efficient tow like so many other fellow horse owners report.



TAKE THE FIRST STEP

to owning a new aluminum Featherlite® horse trailer, and explore how Featherlite moves you – with smart innovations focused on durability, safety, reliability and value. Your final destination: become part of an elite group of satisfied customers who rely on Featherlite to keep their horses safe no matter where they go.



SAFETY

You receive a trailer designed to give your horses a smooth, steady ride plus features like standard deep cushion rubber floor mats. Plus part of keeping your horses safe is providing them extra comforts like additional air flow and light in the horse area with Featherlite's "Light Flo" drop-down feed doors or larger windows behind horses standard on slant loads. Also, Featherlite's patented slam latch dividers feature a quick and secure lock. Dividers not secured properly can swing about, possibly causing injury to horses or upsetting them.

SELECTION

It's easy to find your way to a new horse trailer! Featherlite offers the widest selection of models, most of which are customizable with the Featherlite PerfectFit™ System. Choose your model and then go online at www.fthr.com for specifications, floorplans and available options.

RELIABILITY

You have the peace of mind of owning a trailer with a 10-year limited structural warranty* with 3-year hitch-to-bumper on select models.

FEATHERLITE DROP DOWN FEED DOORS!

FEATURING:

- Heavy duty frame & drop down bars
- Heavy duty hinges
- Lower handle for easier use
- More easily lays flat against trailer

Features may vary depending on trailer models and model year. Some options not available on all models. Some models shown with prior model year graphics.

* 1-year or 3-year hitch to bumper. 10-year warranty applicable to 2013 and newer models. Some restrictions apply. **Transferable Warranty available only on trailer with remaining warranty traded in for a new Featherlite trailer.

BUMPER PULL TRAILERS

Stylish, affordable and compact, Featherlite bumper pulls are the ideal choice for both beginners and veteran horse owners alike.



Featherlite's dressing rooms, fold-up and removable rear tacks, walk through mangers, gravel guards and patented slam latch system are just a few of the favorites with Featherlite bumper pull horse trailer owners. And with the aerodyne nose standard on bumper pulls, towing has never been easier or more economical. Choose from straight load, slant load or combo configurations for your next bumper pull horse trailer from Featherlite.



3-horse with 52" dressing room with graphics, black sheets, wave panels and other options.

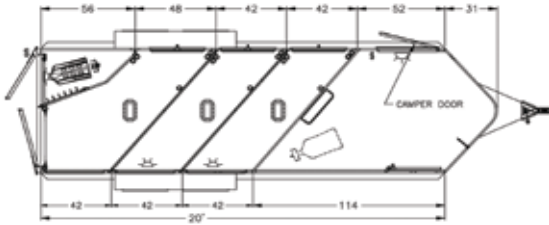

Floorplan: 3-horse with 52" dressing room.

MODEL 9409

2H, 3H or 4H slant load bumper pull with folding rear tack, 2", 24" or 52" dressing room and 6'7" width. The 9409 includes roomy stalls and double rear doors standard. Standard exterior is smooth sides.



2-horse with 52" dressing room, dual color sides, graphics and more.

MODEL 9407

2H straight load bumper pull available in several floorplans, including with mangers and walk through door. Side ramp and rear ramp floorplans also available. Choose from 41" or 48" dressing room.

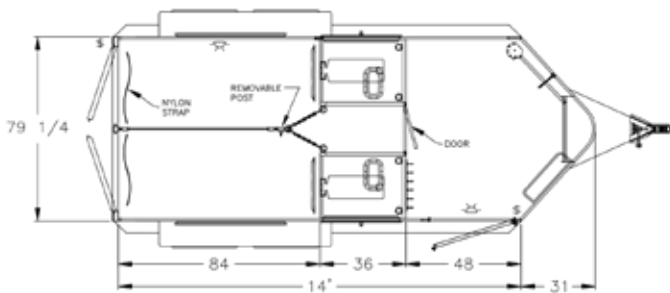

Floorplan: 48" dressing room with mangers & walk-through.



48" dressing room trailer shown with optional charcoal side sheets and aluminum side panels.



41" dressing room trailer shown with dual sides, graphics and aluminum wheels.

* All dimensions are approximate. Some trailers may be shown with options.

BUMPER PULL TRAILERS

MODEL 9651

Featherlite's bumper pull Model 9651 is available in a 2 or 3-horse configuration and features extruded aluminum side panels and air spaces. The trailer is 6'7" wide and 7' tall and comes standard with aluminum wheels and an LED load light.

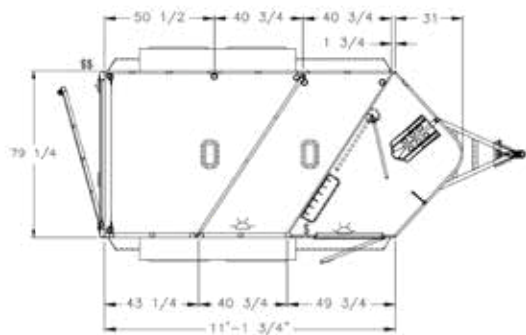

MODEL 7441

Choose from 2H through 4H floorplans with the 7' wide bumper pull slant load horse trailer 7441. Dressing room short wall options are 4" or 24". The trailer features a gravel guard, aluminum wheels, white aluminum lining above the wall rubber and one outside tie ring per horse per side.

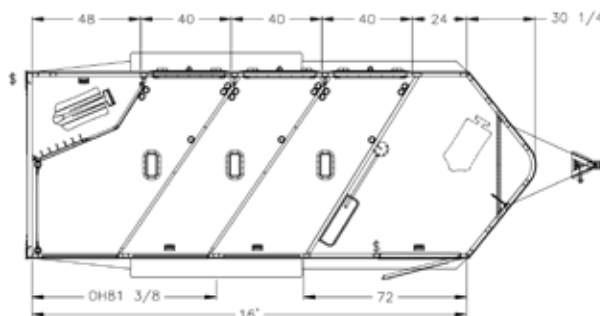

Floorplan: 3H with 24" dressing room.



MODEL 9551

Slant load Model 9551 can be configured to hold 2 to 4 horses with a 7', 7'6" or 8' width. Stall size is 40", 42" or 50". The trailer comes standard with a side load door on 3H & 4H models. Dressing room short wall options range from 24" to 56".

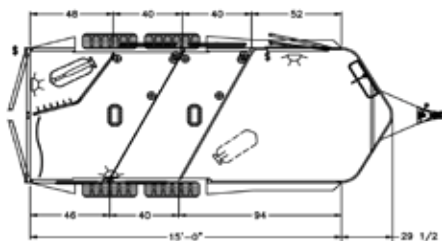

Floorplan: 2-horse with 52" dressing room, 7' width and 40" stalls.



2-horse with 52" dressing room and custom graphics.

WANT MORE INFO & SPECS? GO TO WWW.FTHR.COM

MODEL 9652

Model 9652 straight load bumper pull 2-horse trailer features a rear ramp, aluminum butt/chest bars with padding and aluminum wheels standard. This 6'7" wide trailer design includes a 7' straight load divider with shoulder separator and back leg on a removable post along with a camper door in the trailer's v-nose.

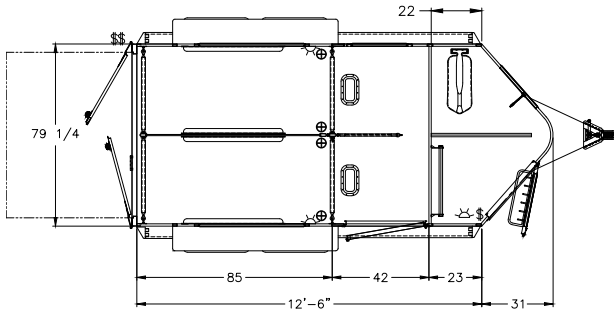

Shown with optional silver sheets, Goodyear tires and additional stop/turn lights.



7442 with 43" dressing room.

MODEL 7442

This straight load 2-horse trailer with rear ramp and double doors above measures 7' wide with an inside height of 7'6". Choice of dressing room sizes includes 51" with walk thru door or 43". The trailer features two 26" x 19" windows in the trailer nose.

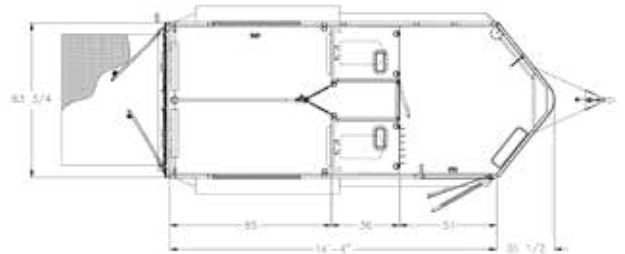

Floorplan: 7442 with 51" dressing room and walk thru door.



MODEL 8107

Model 8107 stock trailer is available with numerous options to customize it as a combo trailer, complete with dressing room, gravel guard and slant dividers.

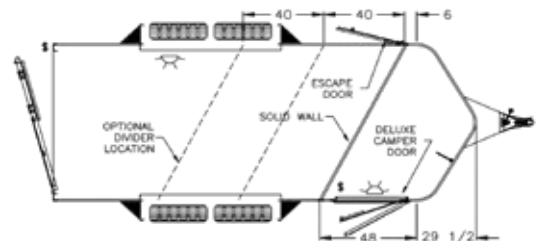

Floorplan: 7' wide slant wall combo conversion Photo: 12' length.

* All dimensions are approximate. Some trailers may be shown with options.

GOOSENECK TRAILERS

Each Featherlite gooseneck model offers a carefully designed package of features to meet your needs.



Featherlite customers get more, including tapered noses, extruded, interlocking aluminum floor, dressing rooms, fold-up and removable rear tacks and Featherlite's own patented, recessed slam latch system for the ultimate in horse trailer safety. Choose from straight load, slant load or combo configurations for your next gooseneck horse trailer from Featherlite.



MODEL 8541

Featherlite's most popular horse trailer is available in configurations of 2H to 6H with numerous dressing room sizes and a choice of a 7' or 7'6" width. White aluminum lining & insulation on walls and ceiling of horse area standard. 40" and 50" stalls available.

3-horse with 52" dressing room, graphics and black sides.

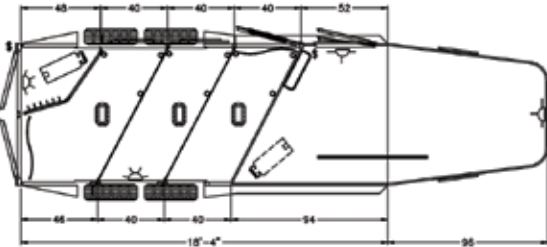

Floorplan: 3-horse with 52" dressing room.



5-horse with 52" dressing room with optional aluminum wheels & charcoal side sheets.

MODEL 7541

The gooseneck Model 7541 is available in 2H through 6H floorplans. This slant load trailer is 7' wide with 40" stalls and a height of 7'. The dressing room has a 56" short wall, and the trailer comes with a convenient side unload door on 3H models and up.



4-horse model with optional silver side sheets.

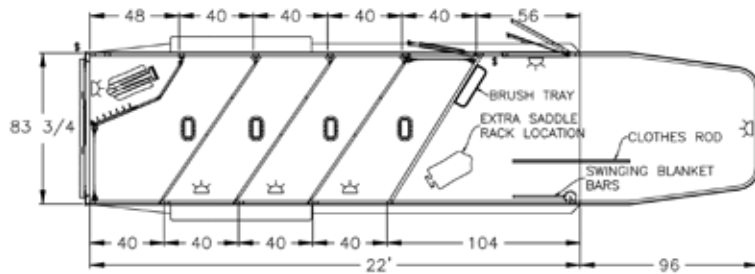

Floorplan: 4-horse model.



3-horse model.

* All dimensions are approximate. Some trailers may be shown with options.

GOOSENECK TRAILERS

MODEL 8413

Versatile gooseneck combo trailer with functional dressing room and full swing rear gate. Available in widths of 7', 7'6" or 8'.

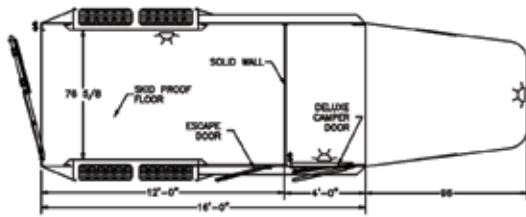

Floorplan: 16' length with straight wall.



24' length with straight wall and spare tire and plexiglass options.



MODEL 9751

Featherlite's gooseneck Model 9751 is available as a 3 or 4-horse model and includes extruded aluminum side panels and air spaces. It has a width of 6'7" and height of 7' with a 2" shortwall dressing room. Standard features include aluminum wheels, 2 outside tie rings per horse and an LED load light.

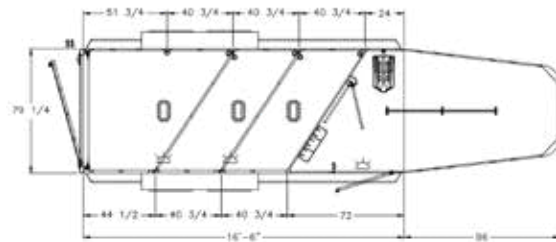

MODEL 9607

Model 9607 is 6'7" wide with an inside height of 7'6". Trailer available with numerous floorplans that include options of feed mangers and side ramps.



2-horse with optional black side sheets and aluminum wheels.

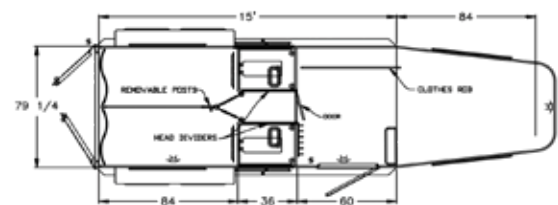

Floorplan: 2-horse with 60" dressing room & mangers.

MODEL 9810

This straight load 6H gooseneck trailer is 8' wide and includes a tack room and side ramp on both sides. Shown with many options.

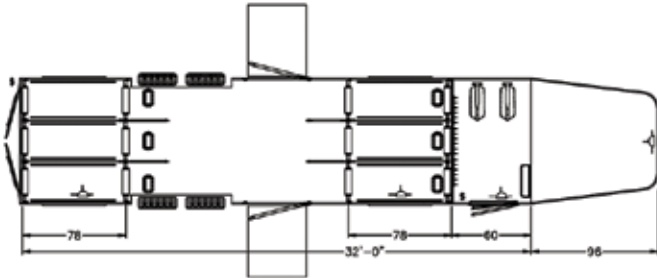

MODEL 9752

Featherlite's straight load Model 9752 horse trailer features a 2+1 configuration with a rear ramp and side ramp. It includes a 24" walk through aluminum door, aluminum butt/chest bars with padding and aluminum lined ceiling. Trailer is 6'7" wide, 7'6" tall and 22' long.

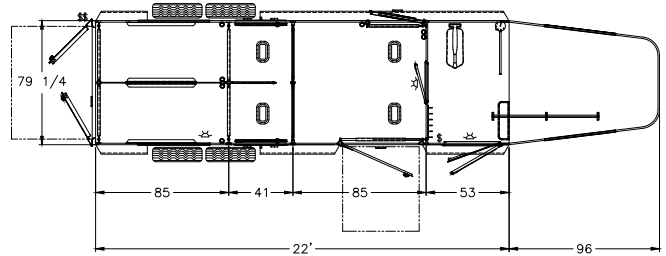

MODEL 8417

Available in 16', 20' or 24' lengths, this economical 6'7" gooseneck combo trailer is equipped with a wood floor and straight or slant wall dressing room.

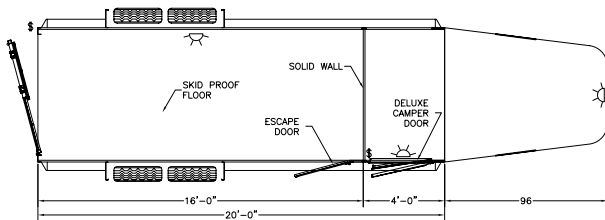

Floorplan: 20' length with straight wall.



20' length with straight wall and options including black side sheets, running boards and plexiglass.

* All dimensions are approximate. Some trailers may be shown with options.

LEGEND HORSE TRAILERS

Super tough and rich with features, the Featherlite Legend Edition captivates the most discerning horse owners.



LEGEND
EDITION
BY FEATHERLITE

True to its roots, Featherlite has built its legendary quality and durability into every element of the new Legend. Highlighted by square cornered windows and doors, the Legend Edition offers even more extraordinary choices to Featherlite trailer owners.

WANT MORE INFO & SPECS? GO TO WWW.FTHR.COM



5-horse with 52" dressing room with optional graphics.

MODEL 8542

This slant load is available in widths and heights of 7' or 7'6" in 2 to 6 horse configurations. Various dressing room sizes available. It is equipped with one tie ring per horse per side, full length one piece aluminum running boards and aluminum brush tray and halter bars.

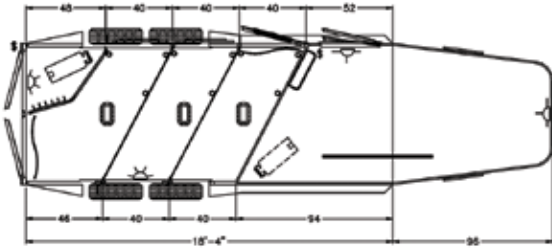

Floorplan: 3-horse with 52" dressing room.



3-horse with 77" dressing room with optional aluminum wheels, polished panels and more.

MODEL 8582

The rugged Legend Edition Model 8582 is available with various living quarters floorplans in 2 to 6 horse configurations. The trailer is 8' wide and 7'6" tall. Square cornered drop down feed doors and camper doors create a unique and heavy duty exterior.

See fth.com for floorplan options.



4-horse with 15' LQ with optional hay rack, generator box and more.



LIVING QUARTERS



FEATHERLITE'S HORSE TRAILERS WITH LIVING QUARTERS offer top-of-the-line furniture and décor, as well as almost any other amenity you might desire. Choose from the widest range of prices, sizes, floorplans and configurations, including space-expanding slideouts. Live well wherever you travel with your horses!

* All dimensions are approximate.
Some trailers may be shown with options.



MODEL 8581

8' wide Featherlite living quarters available with dozens of floorplans and options. White aluminum lining and insulation on walls and ceiling in horse area standard. Shown with options including manger package.

MODEL 7821

This living quarters trailer is 8' wide with an inside height of 7'6". The interior of the 7821 features solid wood cabinets, crown molding, jackknife sofa and solid wood edge countertops. The exterior of the trailer features aluminum wheels, stainless steel front sheets and front corners and a hydraulic jack.



MODEL 7841

Available with 8' and 10' living quarters floorplans, the 7841 measures 7' wide, 7'6" tall and is available in 2H, 3H or 4H floorplans. The trailer comes standard with aluminum wheels, white lined interior, a hydraulic jack and adjustable saddle rack, among other standard features.

MODEL 9821

Featherlite's Model 9821, designed with Featherlite's Liberty Living Quarters, is available in 2, 3 and 4-horse models with an inside height of 7'6" and width of 8'. The Model 9821 features Featherlite's Liberty DX living quarters, which feature quality craftsmanship, designer decors and upgraded standard features.



LIVING QUARTERS



Solid wood cabinetry is standard in the Liberty DX.



Various floorplans and sizes are available in the Featherlite Liberty.



The Featherlite Liberty gives you additional headroom in the bed area.



A jackknife sofa is standard in Liberty interiors.

POPULAR FEATURES & OPTIONS

Featherlite listens to horse owners. That's why they've developed features and options right for you and that help keep your horses safe and comfortable during travel.



FEATHERLITE'S STANDARD FEATURES GIVE YOU MORE



'Light-Flo' Feed Door. Unique in the industry. Featherlite's exclusive "Light Flo" Drop Down Feed Door has redefined horse transportation. These doors provide dramatically more light and air flow into the horse area for easier loading and a calmer, healthier environment for your horses during transport. Now featuring heavier duty frame, bars and hinges plus lower handles for easier use.



'Wave' side panels. The sleek undulating "Wave" design of the side panels is standard on all horse trailers with aluminum side panels.

FEATURES & OPTIONS SHOWN:



Air Flo saddle racks designed with aluminum piping are optional.



Wrapped hay rack with ladder for efficient storage



Optional integrated haypod



Polished 'Wave' side panels are available.



Aerodynamic tapered nose standard



3/4" deep-cushion floor mats in the horse area to reduce stress on horse



Patented recessed slam latch with no posts in horse area



Easy Care Flooring option eliminates need for bedding & cleaning under mats.



Rubber coated tie rings for a quieter, less stressful ride



2-way roof vents on most models (one per horse). Features new design with lining that hugs close to roof.



Deluxe camper door with screen & dead bolt, 36" std. on most models



Sleek full length black stall pads optional



Adjustable saddle racks are standard on most models.



Optional full-width ramp behind doors - versatility for easier unloading



Optional telescoping ladder conveniently stores on side.



The Air Flo divider option creates additional air flow for your horses.



Stylish aluminum wheels in gray or silver optional.



Bright LED dome lights are standard.



LED load light offer style, brightness.



Full length one-piece aluminum running boards

OTHER POPULAR OPTIONS NOT SHOWN:

- Various axle options
- 2" double seal camper door
- Electric/hydraulic brakes
- Stud gates
- 1/2" rubber hanging from the dividers
- Feed bags
- Butt and chest bars
- Blanket bars
- Hat shelf with clothes rack
- Removable shelf in rear tack
- Oscillating fans
- Extra 6" of height or more
- 110 volt outlets (interior and exterior)
- Foot locker
- Camper steps
- Step cleats
- Dog boxes
- Custom designed graphics, paint schemes, complete paint jobs, logos & lettering to fit your needs.
- Dual and tri-colored side sheets



Premium Goodyear® tires are standard on many Featherlite trailers.



Wraparound Lights. Featherlite horse trailers are outfitted with stylish L.E.D. wraparound lights that give your trailer more visibility when traveling down the road. Plus, four stop/turn L.E.D. lights are standard on horse trailers.



Dressing room turf. Turf in the dressing room is thicker, more durable and resists water, mold and mildew.



EZ Lube Axles & Forward Adjusting Brakes. For added convenience and safety, all models with axles of 2.2K through 8K have EZ Lube Axles standard. Forward adjusting brakes are also standard. They automatically adjust to proper clearances during travel allowing you to stop with confidence. It also eliminates the need for manual brake adjustments, saving you time and money.

* All dimensions are approximate. Some trailers may be shown with options. Not all features or options available on all models.

**From mat manufacturer to original purchaser. See dealer for details.

FINAL DESTINATION

Go to www.fthr.com for more trailer specifications, floorplans and available options. Or visit your local Featherlite dealer and be on your way to owning a new Featherlite horse trailer.



Ask your Dealer about loans & leases on new trailers!

- Competitive Rates
- Convenient, Flexible Payment Options
- Fixed Rates



< **Want more information?**
Snap this with your smart phone to visit Featherlite's website.

Contact a Featherlite Dealer for Details. Your area dealer is:

phone 563.547.6000

toll free 800.800.1230

fax 563.547.6100

web www.fthr.com

email besttrailers@fthr.com

address Hwy. 63 & 9, Cresco, IA 52136



All dimensions shown in this brochure are approximate and may vary. Featherlite, Inc. reserves the right to change or alter these specifications without notice. Some trailers shown with optional equipment. ©07/2020 Featherlite, Inc. Printed in the United States.